

Industrial Camera
GP-MF602

Operating Instructions

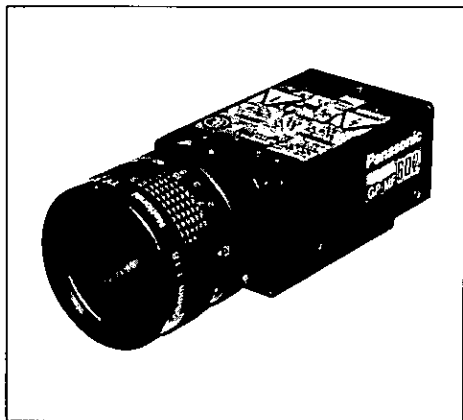

Panasonic®

Before attempting to connect or operate this product,
please read these instructions completely.

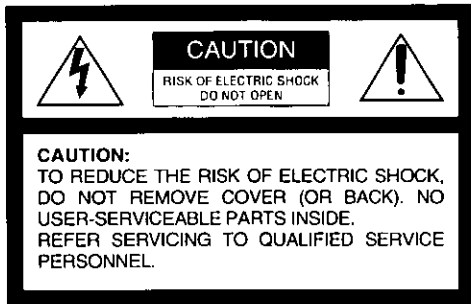

SA 1965

The lightning flash with arrow-head symbol, within an equilateral triangle, is intended to alert the user to the presence of uninsulated "dangerous voltage" within the product's enclosure that may be of sufficient magnitude to constitute a risk of electric shock to persons.



SA 1966

The exclamation point within an equilateral triangle is intended to alert the user to the presence of important operating and maintenance (servicing) instructions in the literature accompanying the appliance.

Warning:

This equipment generates and uses radio frequency energy and if not installed and used properly, i.e., in strict accordance with the instruction manual, may cause harmful interference to radio communications. It has been tested and found to comply with the limits for a Class A computing device pursuant to Subpart J of Part 15 of FCC Rules, which are designed to provide reasonable protection against such interference when operated in a commercial environment.

WARNING: TO PREVENT FIRE OR SHOCK HAZARD, DO NOT EXPOSE THIS APPLIANCE TO RAIN OR MOISTURE.

CONTENTS

PREFACE	1
FEATURES	1
PRECAUTIONS	2
MAJOR OPERATING CONTROLS AND THEIR FUNCTIONS	3
PREPARATIONS	7
SYSTEM CONNECTIONS	8
INSTALLATION OF CAMERA	9
EXTERNAL SYNCHRONIZATION	10
PREVENTION OF BLOOMING AND SMEAR ..	10
SPECIFICATIONS	11
OPTIONAL ACCESSORIES	12

Remove dust on the faceplate of filter glass before mounting the lens on the camera.

The serial number of this product may be found on the bottom of the unit.

You should note the serial number of this unit in the space provided and retain this book as a permanent record of your purchase to aid identification in the event of theft.

Model No. _____

Serial No. _____

PREFACE

The Panasonic GP-MF602 Industrial Camera incorporates a Inter Line Transfer type CCD image sensor.

The GP-MF602 further has an image sensor of 380,000 pixels and 570 lines of horizontal resolution, with smear reduced to a bare minimum.



FEATURES

1. Newly developed multi-function solid state image sensor: 1/2" Inter Line Transfer type CCD image sensor with 768 (H) x 494 (V) pixels.
2. Selectable scanning system :
1-line interlace, 2-line interlace and 2-line sequential are available for the highest quality possible within video processing.
3. External synchronization :
External HD and VD input enable system set-up with external video processors, etc.
4. Frame Reset :
External HD and VD reset signals reset the scanning line to the line number 1.
5. Seven-step of Electronic Shutter or three-step of Electronic Shutter with trigger function selectable.

PRECAUTIONS

1. Do not attempt to disassemble the camera.
To prevent electric shock, do not remove screws or cover. There are no user-serviceable parts inside. Refer servicing to qualified service personnel.
2. Do not expose the camera to rain or moisture, and avoid operation in wet areas.
Take immediate action if the camera should become wet. Turn the power off and request servicing from qualified service personnel. Moisture can damage the camera and create danger of electric shock.
3. Do not drop anything inside the camera.
Dropping metal for example inside the camera could permanently damage the unit. If anything is dropped inside the camera, turn off the power immediately and refer to the qualified service personnel.
4. Never aim the camera at bright objects.
Whether the camera is in use or not, never aim it at the sun, or other extremely bright objects as this could cause blooming.
5. Do not use the camera beyond its temperature, humidity or power source ratings. This camera is designed for indoor use.
 - (a) The ambient temperature must not range beyond 14°F - 122°F (-10°C - +50°C).
 - (b) Avoid using the camera when the humidity is above 90%.
 - (c) The input power source must be DC 12V, 190mA.

MAJOR OPERATING CONTROLS AND THEIR FUNCTIONS

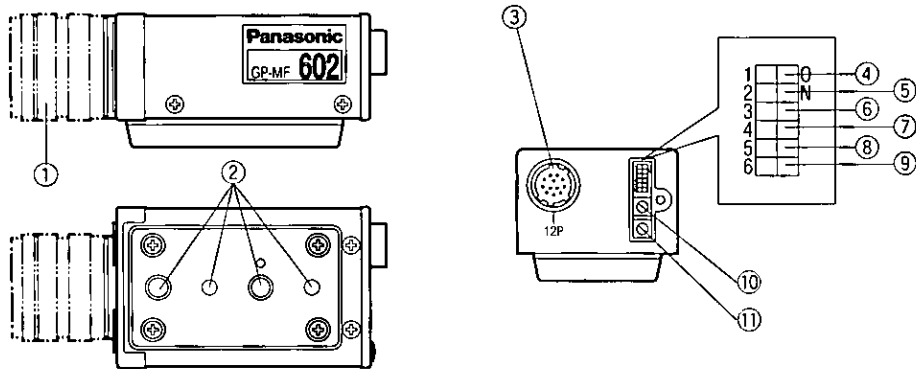

1. 1/2" Manual Iris Lens (Sold Separately)

2. Mounting Holes

There are two threaded holes (1/4") for mounting the camera onto the tripod and two or more threaded holes (No.832 UNC) for mounting the camera onto the mounting bracket.

3. Camera Connector (12-pin)

This is connected with the optional Camera Cable GP-CA34 , GP-CA33, GP-CA59 or GP-CA60.

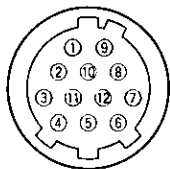

CAUTION: CONNECT THIS TO A DC 12V CLASS 2 POWER SUPPLY ONLY.

Pin No.	Description
1	Ground
2	+12V IN*
3	Ground for Video Out
4	Video Out
5	Ground for HD
6	HD In/Out
7	VD In/Out or frame reset in
8	Ground
9	No connection
10	Ground for Read out/Inhibit
11	Read out/Inhibit
12	Ground for VD

4. Switch 1 (1/ON) 1 ON

This switch is used to select the Field or Frame Accumulation.

ON: Field Accumulation
1: Frame Accumulation

5. Switch 2 (2/ON) 2 ON

This switch is used to select the Shutter Trigger A or B mode.

A mode:

Set this switch to the ON position.
 Set the Switch 1 to the ON position.
 Supply the frame reset signal into the pin-7 of the Camera Connector(3).
 The frame reset signal is latched by the internal HD signal.
 Set the Switch 3, Switch 4 and Switch 5 to the suitable position according to the following table. The 3 kinds of shutter speeds can be selected.

Switch			Shutter Speed (seconds)
5	4	3	
ON	OFF	ON	1/2000
ON	ON	OFF	1/4000
ON	ON	ON	1/10000
Others			Not specified

B mode :

Set this switch to the ON position.

Set the Switch 1 to the 1 position.

The shutter speed of approx. 1/2000 sec. is obtained regardless of Switch 3, Switch 4 or Switch 5 setting.

6. **Switch 3 (3/ON)** 3 ON

7. **Switch 4 (4/ON)** 4 ON

8. **Switch 5(5/ON)** 5 ON

These switches (Switch 3, Switch 4 and Switch 5) are used to set the shutter speed as shown below.

Switch			Shutter Speed (seconds)
5	4	3	
OFF	OFF	OFF	NORMAL
OFF	OFF	ON	1/125
OFF	ON	OFF	1/250
OFF	ON	ON	1/500
ON	OFF	OFF	1/1000
ON	OFF	ON	1/2000
ON	ON	OFF	1/4000
ON	ON	ON	1/10000

Note: The shutter speed does not function accurately under the non-interlaced synchronization.

9. **Switch 6 (6/ON)** 6 ON

This is the On/Off Switch for the Gain Up level control.

ON: The gain up level can be controlled from 0 to 6 dB by using the Manual Gain Control(10).

6: The gain up level control is not available.

10. **Manual Gain Control**

When setting the Switch 6 to the ON position, this control activates.

The control range of gain up level is 0 - 6 dB.

11. **Pedestal Control**

The pedestal level can be controlled from 15mV to 80 mV.

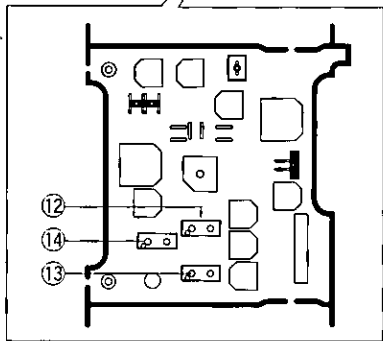
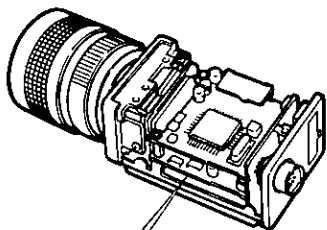

12. Gamma On/Off Switch ON OFF
(SW 1)

The gamma level of 0.6 or 1.0 can be selected by this switch.

ON: 0.6

OFF: 1.0

13. HD/VD Termination Switch OFF ON
(SW 3)

Set this switch to the ON position to terminate the HD/VD signals with 75 ohms.

14. HD/VD Output Switch IN OUT
(SW 4)

IN: The HD/VD signal can be supplied in this camera.

OUT: The HD/VD signal is output from this camera.

Note: The equipments connected with this unit should be set to the Hi-Z.

PREPARATIONS

1. Power Supply for Camera

Prepare a regulated DC power supply which can supply DC 12 V \pm 10% DC 190 mA or more current and rated CLASS 2.

2. Lenses

Be sure to use the optional manual iris lens having the following items.

Focus : Adjustable

Lens Weight : Less than 300 g (0.66 lbs.)

Note: If the lens weight exceed 300 g (0.66 lbs.), the camera and lens should be secured.

Mount : C-mount

Lens mount should be as shown in the diagram, otherwise the lens will damage the camera.

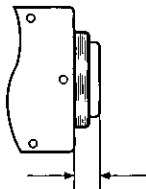

Less than 5/6" (Less than 8 mm)

3. Top and Switch Covers Removal

Caution: The following preparation should be made by qualified service personnel or system installers.

For selecting Gamma On/Off Switch, HD/VD Termination Selection Switch or HD/VD Output Switch, the top cover of this camera should be removed.

And for setting the switch 1, 2, 3, 4, 5 or 6, remove the switch cover on the rear panel should be removed.

Remove the fixing screws as shown below.

Remove 6 screws.

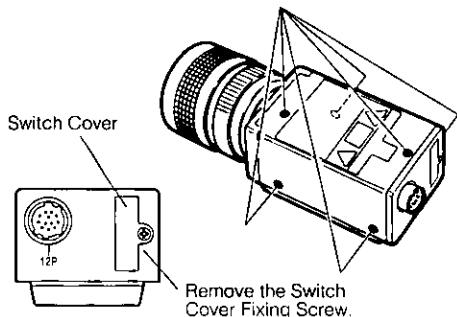

SYSTEM CONNECTIONS

Caution: Keep the Power Switches of all units in the OFF position during connections.

1. Connect the optional Camera Cable GP-CA34 between the Camera Connector of this camera and the DC 12V Class 2 Power Supply(Sold separately).
2. Connect the Video Connector of the GP-CA34 to the Video Monitor.

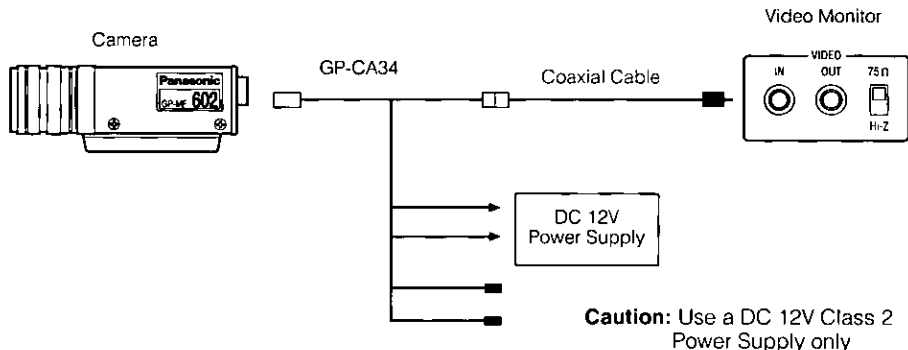

INSTALLATION OF CAMERA

1. Mounting from top

This camera is originally designed to be mounted from the top, as shown. The hole is the standard photographic pan-head screw size (1/4" - 20).

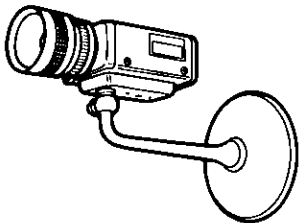

2. Mounting from bottom

Remove the mount adaptor on the top of the camera by removing 3 fixing screws. Attach the mount adaptor to the bottom as shown in the diagram, then mount the camera on the mounting bracket.

Make sure that the 3 original screws are used when mounting the mount adaptor ; longer type screws will break the inner component.

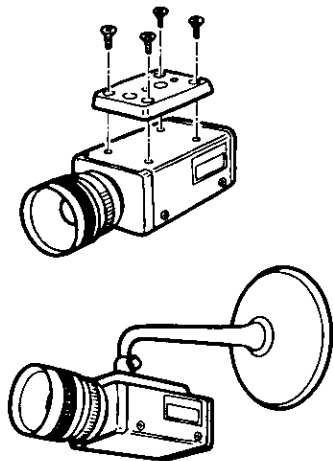

EXTERNAL SYNCHRONIZATION

1. 2 : 1 Interlace

The GP-MF602 operates in the 2 : 1 interlace mode when the external 2 : 1 interlaced HD and VD signals are supplied to the pin-6 and pin-7 of the Camera Connector(12-pin)

2. Non-interlace

The GP-MF602 operates in the non-interlace mode when the external non-interlaced HD and VD signals are supplied to the pin-6 and pin-7 of the Camera Connector(12-pin).

Note: If the picture will be disturbed, be sure to match the phase of falling edges of the external HD and VD.

PREVENTION OF BLOOMING AND SMEAR

When the camera is aimed toward spot lights or other bright lights and light reflecting objects. A vertical stripe (smear) or blooming may appear therefore the camera should be operated carefully in the vicinity of extremely bright objects to avoid the vertical stripe (smear) or blooming.

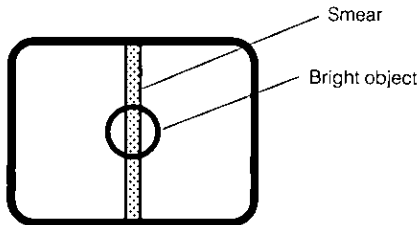

SPECIFICATIONS

Pick-up Device :	Inter Line Transfer type CCD with 768 (H) x 494 (V) pixels.
Image Size :	1/2" (7.95 (H) x 6.45 (V) mm) 2 : 1 interlace 1-line interface (Frame accumulation) 2 : 1 interlace 2-line interface (Field accumulation) 2-line sequential (at non-interlaced external HD/VD)
Synchronization :	Internal or External (Selectable Automatically) Internal : Built-in sync generator External : 4.0 Vp-p / 75 ohms Horizontal drive and Vertical drive pulses for 2 : 1 interlace or sequential scanning
External Reset :	External signal (4.0 Vp-p/75 ohms, negative) supplied to EXT VD IN connector can be used as reset signal
Horizontal Resolution :	570 lines at center
Minimum Illumination :	0.05 footcandles (0.5 lux), (F1.4, Manual Gain Max, γ ON, 2 : 1 interlace, without shutter)
Signal to Noise Ratio:	56 dB Typical (Fix Gain, γ OFF, 2:1 interlace without shutter)
Gamma :	1.0 or 0.6 selectable internally
Gain Selection :	0 dB, Manual selectable internally
Electronic Shutter :	7-step (1/125 to 1/10,000) at normal. 3-step (1/2,000 to 1/10,000) at Shutter Trigger-A. Approx. 1/2,000 at Shutter Trigger-B.
Lens Mount :	C-mount

Vibration Resistance :	8 G (10 Hz - 150 Hz) (2 hours each for three axes)
Shock Resistance :	80 G (IEC 68) *IEC=International Electrotechnical Commission
Power Source :	DC + 12V, 190 mA
Ambient Temperature :	14°F - 122°F (-10°C - +50°C)
Dimensions :	1-3/4"(W) x 1-1/8"(H) x 2-13/16"(D) [44(W) x 29(H) x 72(D) mm]
Weight :	0.46 lbs. (155g) (Camera Only)

Dimensions and weight indicated are approximate values.
 Specifications are subject to change without notice.

OPTIONAL ACCESSORIES

Camera Cable	GP-CA34
	GP-CA33
	GP-CA59
	GP-CA60

Panasonic

Broadcast & Television Systems Company

Division of Matsushita Electric Corporation of America

INDUSTRIAL CAMERA DIVISION

Executive Office: One Panasonic Way 4H-2, Secaucus, New Jersey 07094 (201) 392-6674

MATSUSHITA ELECTRIC OF CANADA LIMITED

5770 Ambler Drive, Mississauga, Ontario, L4W 2T3 Canada (905) 624-5010

PANASONIC SALES COMPANY

DIVISION OF MATSUSHITA ELECTRIC OF PUERTO RICO, INC.

San Gabriel Industrial Park, 65th Infantry Ave. KM. 9.5 Carolina, Puerto Rico 00630 (809) 750-4300

N0295-0

YWV8QA3541AN

Printed in Japan

Ⓝ 13

Industrial Camera
GP-MF602

Operating Instructions



Panasonic®

Before attempting to connect or operate this product,
please read these instructions completely.